

# THE DEC POLICY SYSTEM



New York State  
Department of Environmental Conservation

## PROGRAM POLICY

Department ID:  
DEP-00-2

Program ID:  
n/a

Title: Assessing and Mitigating Visual Impacts

Issuing Authority: Article 8, 49

Name: Jeffrey Sama

Title: Director

Signature: /s/ \_\_\_\_\_ Date: 7/31/00

Issuance Date: 7/31/00

Originating Unit: Division of Environmental Permits

Office/Division: Environmental Permits

Unit:

Phone: (518) 402-9167

Latest Review Date (Office Use):

Abstract: Facilities regulated by the Department of Environmental Conservation located in visual proximity to sensitive land uses can produce significant visual impacts. This policy and guidance defines what visual and aesthetic impacts are, describes when a visual assessment is necessary and how to review a visual impact assessment, differentiates State and local concerns, and defines avoidance, mitigation and offset measures that eliminate, reduce, or compensate for negative visual effects. A glossary of terms is provided for reference.

## I. Purpose

This memorandum provides direction to Department staff for evaluating visual and aesthetic impacts generated from proposed facilities. This guidance defines State regulatory concerns and separates them from local concerns. There is nothing in this program policy that eliminates or reduces the responsibility of an applicant to local agencies to address local visual or aesthetic concerns. In addition, this program policy does not relieve applicants from requirements of other State agencies, such as Department of State Coastal Zone Program or Department of Public Service. This guidance will also define important technical concepts and provide a mechanism for complying with the balancing provisions of the State Environmental Quality Review Act (SEQR) with respect to environmental aesthetics.

## II. Background

An ever expanding body of research has demonstrated that environmental aesthetic values are shared among the general population. This research finds that such values are not idiosyncratic, random, or arbitrary. For example, millions of people visit Niagara Falls for our shared appreciation of its beauty.

Many places have been recognized for their beauty and designated through Federal or State democratic political processes, reinforcing the notion that environmental aesthetic values are shared. Recognition of aesthetic resources also occurs at local levels through zoning, planning or other public means. That these special places are formally recognized is a matter of public record. This guidance contains a

generic listing of all aesthetic resources of statewide significance and serves as the template from which aesthetic issues of State concern can be distinguished from local issues. Generally, it is staff's responsibility to identify and mitigate impacts to Federal and State designated aesthetic resources. With respect to local resources, Department staff should defer to local decision makers, who are likely to be more familiar with and best suited to address them.

### **III. Policy**

In the review of an application for a permit, Department staff must evaluate the potential for adverse visual and aesthetic impacts on receptors outside of the facility or property. When a facility is potentially within the viewshed of a designated aesthetic resource, the Department will require a visual assessment, and in the case where significant impacts are identified, require the applicant to employ reasonable and necessary measures to either eliminate, mitigate or compensate for adverse aesthetic effects.

### **IV. Responsibility**

The environmental analyst, acting as project manager, for review of a new application must assure that visual and aesthetic impacts are properly evaluated by the applicant. For new permits or significantly modified permits, staff must determine the potential significance of the action pursuant to SEQR.

In the review of an application for a permit, staff must evaluate the potential for adverse aesthetic impacts to sensitive places. Sensitive places of statewide concern are listed in this guidance (see V. Procedure). From the State's perspective there may be a significant impact if one or more of the listed places lies within the viewshed of a proposed project. From a local perspective there may be a significant impact if a local resource lies within the project's viewshed. This simple concept may help staff and decision makers distinguish local concerns from State concerns, and public concerns from individual expressions of concern.

With respect to aesthetics, an individual citizen's expression of concern is usually based on the belief that a property or particular "neighborhood" lies within the viewshed of a proposed project. This is different from the concerns of the public at large which has a stake in aesthetic resources recognized as having designated value under the public domain.

Significant impacts are identified and confirmed by staff during the review of an application. SEQR obligates the Department to mitigate such impacts to the maximum extent practicable [6NYCRR Part 617.11(d)(5)]. Local involved agencies must do the same with respect to local resources and likewise comply with Article 8 of the ECL and 6NYCCR Part 617. Impacts to aesthetic resources of statewide concern may require more substantial mitigation strategies to achieve project approval. Mitigation costs and practicality of the mitigative measures must be weighed in the balancing required by the State Environmental Quality Review Act.

Local resources are frequently designated through local zoning and planning processes. Accordingly, local jurisdictions may require additional and somewhat different information than the Department. The legislature has recently recognized and addressed this jurisdictional difference. In 1999, the Legislature, revised Article X of the Public Service Law to eliminate a DEC requirement to testify on behalf of local

jurisdictions concerning the impacts of power plant siting. In doing so, they explicitly eliminated the requirement that DEC staff testify with regard to local jurisdictional needs.

## V. Procedure

Staff must assure that the full scope of visual and aesthetic concerns are addressed. This includes impacts from all project components and their operation on all inventoried resources. In addition, an equitable level of expectations between the potential significance of the impact, the degree of sophistication of the analysis required of applicant and appropriate level of mitigation strategies must be established. The goal of visual assessment is to reveal impacts and effective mitigation strategies. Small scale, low budget projects should not be burdened with the costs of sophisticated visual analyses. In these instances, it is generally more effective to reserve applicant investments for mitigation rather than complex visual assessments. Simple line-of-sight profiles may suffice for revealing impacts and potential mitigation strategies (see appendix A for an illustration of their use).

Staff must take certain basic steps to assure that visual concerns have been fully addressed in each application. Those steps are:

- A. Verify the applicant's inventory of aesthetic resources.
- B. Verify the applicant's visual assessment, using either graphic viewshed and line-of-sight profile analysis as illustrated in Appendix A, or more sophisticated visual simulations and digital viewshed analysis, as needed.
- C. Determine or verify the applicant's assessment of the potential significance of the impact.
- D. Confirm that applicant's mitigation strategies are reasonable and are likely to be effective, or assure mitigation by requiring the applicant to submit a design that includes the required mitigation, or, impose permit conditions consistent with those mitigation requirements.

A discussion of each follows:

### A. Inventory of Aesthetic Resources.

It is important to note that all significant scenic and aesthetic resources may not have yet been designated in New York State. However, for the purposes of this policy all aesthetic resources of statewide significance may be derived from one or more of the following categories:

- 1) A property on or eligible for inclusion in the National or State Register of Historic Places [16 U.S.C. § 470a et seq., Parks, Recreation and Historic Preservation Law Section 14.07]; e.g. Trinity Church in Manhattan, Schuyler Mansion in Albany;
- 2) State Parks [Parks, Recreation and Historic Preservation Law Section 3.09]; e.g. Grafton Lakes State Park, Rensselaer County;
- 3) Urban Cultural Parks [Parks, Recreation and Historic Preservation Law Section 35.15];

- 4) The State Forest Preserve [NYS Constitution Article XIV]; Adirondack and Catskill Parks;
- 5) National Wildlife Refuges [16 U.S.C. 668dd], State Game Refuges and State Wildlife Management Areas [ECL 11-2105]; e.g. Montezuma National Wildlife refuge; Perch River Wildlife Management Area, Jefferson County;
- 6) National Natural Landmarks [36 CFR Part 62]; e.g. Iona Island Marsh, Hudson River, Rockland County;
- 7) The National Park System, Recreation Areas, Seashores, Forests [16 U.S.C. 1c]; e.g. Gateway National Recreation Area, Staten Island; Finger Lakes National Forest, Schuyler County;
- 8) Rivers designated as National or State Wild, Scenic or Recreational [16 U.S.C. Chapter 28, ECL 15-2701 et seq.]; e.g. Cedar River (Wild), Ampersand Brook (Scenic); West Branch of the Ausable River (Recreational);
- 9) A site, area, lake, reservoir or highway designated or eligible for designation as scenic [ECL Article 49 or DOT equivalent and APA. Designated State Highway Roadside; e.g. Storm King Highway (Article 49 Scenic Road), Rockland county];
- 10) Scenic Areas of Statewide Significance [of Article 42 of Executive Law]<sup>1</sup>; e.g. Catskill-Olana SASS;
- 11) A State or federally designated trail, or one proposed for designation [16 U.S.C. Chapter 27 or equivalent]; e.g. Appalachian Trail;
- 12) Adirondack Park Scenic Vistas; [Adirondack Park Land Use and Development Map]
- 13) State Nature and Historic Preserve Areas; [Section 4 of Article XIV of the State Constitution];
- 14) Palisades Park; [Palisades Interstate Park Commission]; e.g. Harriman State Park;
- 15) Bond Act Properties purchased under Exceptional Scenic Beauty or Open Space category; e.g. Star Hill, Oneida County.

Note: The Hudson River has recently been designated an “American Heritage River” by a Presidential Order under [PL 91-190]. The details and criteria of the program as they may relate to this policy are currently under review.

## B. Visual Assessments.

---

<sup>1</sup> State Coastal Policies number 24 and 25 derived in part from Section 912 of Article 42 of the Executive Law define the criteria that, when properly employed, assure project consistency with coastal zone management objectives. Such policies are consistent with the review mechanisms contained in this DEC policy. Also for reference is the July 1993 DOS SASS publication for Columbia-Greene, Catskill-Olana, Estates District, Ulster North, Esopus-Lloyd, and the Hudson Highlands.

In all visual assessments, significant resources must be identified along with any potential adverse effects on those resources from the proposed project. If, in staff's judgement, a place designated in any of the above categories may lie in the viewshed of the proposed project then a visual assessment should be required to confirm or refute this potential. At a minimum a line-of-sight-profile, or, depending upon the scope and potential significance of the activity, a digital viewshed may be used to determine if a significant property is within the potential viewshed of the proposed project (see the Appendix A attached for guidance on how to construct and use a line-of-sight profile). Staff must then review the applicant's visual assessment for adequacy, accuracy and thoroughness. The control points (see glossary for definition) must be established by staff and should include a worst case scenario. Worst case here means establishing the control points that reveal any project visibility at an aesthetically significant place. Most of the time, though not always, high points reveal worst case. For example, the tallest facility component (e.g. combustion exhaust stack), may be the control point at the project end of the profile, while a high point of ground upon which the observer stands within a State Park may be the control point at the resource end of the profile.

With respect to determining the radius of the impact area to be analyzed, there has been a general guideline for large actions that it is usually "safe" to use 5 miles. The 5 mile distance probably owes its origins to the U.S. Forest Service "distance zones" set forth in their landscape management journal written in 1973<sup>2</sup> (5 miles is still largely considered "background," i.e. distances at which most activities are not a point of interest to the casual observer). However, for very large activities, such as power plants (particularly those that generate wet cooling tower plumes), and large landscape alterations, greater distances have been shown to be important in some landscape settings, and must be considered. In those instances, applicants must document to the satisfaction of staff that impacts beyond five miles to listed resources have been considered. They must also provide a clear demonstration that impact to any resource of statewide concern is insignificant. Such demonstrations may be convincing if resource inventories beyond 5 miles are coupled with line-of-sight profiles (see Appendix A for a complete discussion of these graphic tools) or other accepted visual criteria, such as computer simulations, analogous comparative studies or worst case presentations.

#### C. Significance.

Aesthetic impact occurs when there is a detrimental effect on the perceived beauty of a place or structure. Significant aesthetic impacts are those that may cause a diminishment of the public enjoyment and appreciation of an inventoried resource, or one that impairs the character or quality of such a place. Proposed large facilities by themselves should not be a trigger for a declaration of significance. Instead, a project by virtue of its siting in visual proximity to an inventoried resource may lead staff to conclude that there may be a significant impact. For example, a cooling tower plume may drift between viewers standing on an overlook at a State Park thereby blocking the view of the panorama. Staff must verify the potential significance of the impact using the qualities of the resource and the juxtaposition (using viewshed and or line-of-sight profiles) of the proposal as the guide for the determination.

#### D. Mitigation.

---

<sup>2</sup> U.S. Forest Service, Agricultural Handbook Number 434, Feb. 1973

Mitigation may reduce or eliminate the visibility of the project or alter the project's effect on the scenic or aesthetic resource in some way. It is usually easier to deal with the visibility of the project than its composition to achieve mitigation. Altering the composition of a project lies within the realm of professional designers. When given the opportunity, however, staff should encourage applicants to design aesthetically compatible projects that incorporate environmentally friendly design principles and components, as may be employed from the mitigation menu below.

Mitigation strategies can be categorized into three general groups as outlined below.

- 1) Professional Design and Siting.
  - a) Screening
  - b) Relocation
  - c) Camouflage/Disguise
  - d) Low Profile
  - e) Downsizing
  - f) Alternate Technologies
  - g) Non-specular materials
  - f) Lighting
- 2) Maintenance
  - a) Decommissioning
- 3) Offsets

A discussion of each follows:

1. Professional Design and Siting. A properly sited and designed project is the best way to mitigate potential impacts. Under optimum circumstances a project can be sited in a location which precludes the possibility of having an aesthetic resource within its viewshed. Also, through sensitive design treatment, elements of particular concern may be sited or dimensioned in a way that reduces or eliminates impacts on significant resources. Sometimes circumstances prevent the realization of optimal siting and sometimes engineering, economic or other constraints preclude optimum dimensioning or other appropriate design treatments. Under those circumstances, other mitigation strategies should be considered.

Staff should assure effective mitigation is thoroughly explored by requiring project sponsors to consider the following tools to mitigate impacts:

a. Screening. Screens are objects that conceal other objects from view. They may be constructed of soil, rocks, bricks, or almost anything opaque. Vegetation can, despite its visual porosity, function as a screen when a sufficient mass is employed. Screens may be natural, e.g. vegetation, or artificial, e.g. fences and walls. Screens may appear natural e.g. wood, stone, or may appear artificial, e.g. plastic, metal. In natural settings it is generally better to employ natural materials, while in urban places designers may employ a broader range of materials.

Screens constructed from soil are called berms. Berms may appear natural e.g. blend with nearby topography, or appear artificial e.g. geometrical or symmetrical shape. Each

may be employed depending upon the overall design intent. Berms may be vegetated or not vegetated depending upon their particular function, e.g. spill containment and/or screening.

Properly sized and placed screens may completely conceal an object, while improperly sized and placed screens may fail to conceal. Screens may block desirable views when improperly placed (see Appendix A to see how screen placement is important).

Screens are not necessarily buffers and buffers are not necessarily screens. A buffer may attenuate noise, soften a landscape or provide other functions that may or may not include screening.

Screens possess line, form, texture, planes and color, and therefore, have their own aesthetic qualities. At times, they may be more impacting than the object to be concealed. Screens may draw attention to the object to be concealed. Screens may physically connect two similar or dissimilar areas.

b. Relocation. A facility component may be relocated to another place within the site to take advantage of the mitigating effects of topography and vegetation.

c. Camouflage/Disguise. Colors and patterns of color may conceal an object or its identity. Disguise may take many forms, and is limited only by the imagination of the project designers. As an example, communication towers can be disguised as trees, flagpoles, barn silos, church steeples, or any other “in-character” structure depending upon circumstances.

d. Low Profile. Reducing the height of an object reduces its viewshed area.

e. Downsizing. Reducing the number, area or density of objects may reduce impacts.

f. Alternate Technologies. Substituting one technology for another may reduce impacts (e.g. dry cooling tower technology versus wet cooling tower technology).

g. Non-Specular Materials. Using building materials that do not shine may reduce visual impacts.

h. Lighting. With respect to regional issues, such as a tall combustion exhaust stack or radio tower, the Federal Aviation Administration (FAA) requires certain lighting for public transportation safety. These impacts may be considered unavoidable unless lower profiles can be achieved. Applicants should also document that they have consulted with and met all applicable lighting standards under local jurisdiction. Consideration should be given to off-site light migration, glare and “sky glow” light pollution. Lighting requirements, through best engineering practices, should not exceed the functional requirements of the project.

2. Maintenance. How a landscape and structures in the landscape are maintained has aesthetic implications. “Eyesores” result from neglect. This should be part of any mitigation strategy.

a. Decommissioning. Removing an object from the landscape after its useful life is over, reduces the duration of a visual impact (see page 9 for further discussion).

3. Offsets. Correction of an existing aesthetic problem identified within the viewshed of a proposed project may qualify as an offset or compensation for project impacts. A decline in the landscape quality associated with a proposed project can, at least partially, be "offset" by the correction. In some circumstances a net improvement may be realized (see page 9 for further discussion).

An applicant may assert that all economic and effective mitigation strategies have been incorporated into the proposed design and, when properly designed, such self-imposed mitigation should effectively mitigate any negative effects on a listed resource. However, if staff concludes that significant impacts remain then staff must still ensure that impacts are minimized. In this regard, staff should first investigate visibility mitigation strategies. Manipulating design elements to achieve adequate mitigation usually lies within the purview of professional designers.

Staff should not try to judge the quality of a design nor its effect on the aesthetics of the listed resource unless they are qualified to do so. Such qualifications normally include academic or other accepted credentials in architecture or landscape architecture. Nevertheless, it is the burden of the applicant to provide clear and convincing evidence that the proposed design does not diminish the public enjoyment and appreciation of the qualities of the listed aesthetic resource. Staff can and should review the strength or merit of such proof. An applicant's mere assertion that the design is in harmony with or does not diminish the values of the listed resource is insufficient for the purposes of reaching findings. Instead, an applicant must demonstrate through evidence provided by others e.g. recognized architectural review boards, comparative studies that are clearly analogous, or other similar techniques, that the public's enjoyment and appreciation of the qualities of the aesthetic resource are not compromised.

Staff must be assured that consistent with social, economic and other essential considerations, the action is one that avoids or minimizes adverse impacts to the maximum extent practicable. This can be accomplished by asking and responding affirmatively to the following questions.

- 1) Was the full mitigation menu considered?
- 2) Will those mitigation strategies selected be effective?
- 3) Were the costs of mitigation for impacts to other media considered and were those mitigation investments prioritized accordingly?
- 4) Are the estimated costs of all mitigation insignificant (for example, are the costs of visual mitigation taken together with all other mitigation less than 10% of the total project cost?)
- 5) Were the mitigation strategies employed consistent with previous similar applications? If not, was the reasoning for any changes reasonable and justified?
- 6) Was the mitigation cost effective? For example, if fully mature vegetation with an immediate screening effect costs 10 times the amount that less mature vegetation would cost, is it appropriate to require the less costly option if its full screening effect can be realized in just, say, 3 years? (See Appendix A for details concerning this subject).
- 7) Were offsets and decommissioning considered?

It is important to bring the project sponsor into the discussion of mitigation strategies. If more than one mitigation strategy meets all environmental protection needs, the applicant's needs and preferences should be considered.

It is preferred that all mitigation options selected be specified in the applicant's plans for Department review. The plans should sufficiently depict readily understandable and enforceable details. Adherence to such plans should then become a permit condition. During and after facility construction, staff should visit the site and ensure that all mitigation strategies detailed in the plans and specifications have been adequately incorporated into the facility design.

If all mitigation options available from the menu are considered, applied where appropriate, and those applied are cost effective, then one can assert that impacts have been minimized to the maximum extent practicable. However, the residual impact after all such strategies have been employed may still be significant. Offsets should then be considered to help achieve the balancing required of SEQR. Finally, decommissioning options may be considered that reduce the duration of impacts for projects with severe residual impacts. A discussion of each follows:

#### 1. Offsets.

Offsets should be employed in sensitive locations where significant impacts from the proposal are unavoidable, or mitigation of other types would be uneconomic and mitigation to be used is only partially effective. Offsets should be employed when significant improvement can be expected at reasonable cost. An example of an offset might be the removal of an existing abandoned structure that is in disrepair (i.e. an "eyesore") to offset impacts from a proposal within visual proximity to the same sensitive resource.

#### 2. Decommissioning.

Decommissioning may take many forms, and other disciplines in Department program areas may have an interest in decommissioning. However, from the perspective of aesthetics, three are of most significance: 1) the total removal from the site of all facility components and restoration to an acceptable condition, usually with attendant revegetation; 2) partial removal of facility components, such as elimination of visually impacting structures; and 3) conditions designed to maintain an abandoned facility and site in an acceptable condition that precludes "eyesores" or site and structural deterioration. Applicants should provide such plans when deemed necessary.

### Glossary

**Aesthetic impact:** Aesthetic impact occurs when there is a detrimental effect on the perceived beauty of a place or structure. Mere visibility, even startling visibility of a project proposal, should not be a threshold for decision making. Instead a project, by virtue of its visibility, must clearly interfere with or reduce the public's enjoyment and/or appreciation of the appearance of an inventoried resource (e.g. cooling tower plume blocks a view from a State Park overlook).

**Aesthetically significant place:** A formally designated place visited by recreationists and others for the express purpose of enjoying its beauty. For example, millions of people visit Niagara Falls on an annual basis. They come from around the country and even from around the world. By these measurements,

one can make the case that Niagara Falls (a designated State Park) is an aesthetic resource of national significance. Similarly, a resource that is visited by large numbers who come from across the state probably has statewide significance. A place visited primarily by people whose place of origin is local generally is generally of local significance. Unvisited places either have no significance or are "no trespass" places.

**Aesthetic Quality:** There is a difference between the quality of a resource and its significance level. The quality of the resource has to do with its component parts and their arrangement. The arrangement of the component parts is referred to as composition. The quality of the resource and the significance level are generally, though not always, correlated.

**Atmospheric perspective:** Even on the clearest of days, the sky is not entirely transparent because of the presence of atmospheric particulate matter. The light scattering effect of these particles causes atmospheric or aerial perspective, the second important form of perspective. In this form of perspective there is a reduction in the intensity of colors and the contrast between light and dark as the distance of objects from the observer increases. Contrast depends upon the position of the sun and the reflectance of the object, among other items. The net effect is that objects appear "washed out" over great distances.

**Control Points:** The two end points of a line-of-sight. One end is always the elevation of an observer's eyes at a place of interest (e.g. a high point in a State Park) and the other end is always an elevation of a project component of interest (e.g. top of a stack of a combustion facility or the finished grade of a landfill).

**Line-of-sight profile:** A profile is a graphic depiction of the depressions and elevations one would encounter walking along a straight path between two selected locations. A straight line depicting the path of light received by the eye of an imaginary viewer standing on the path and looking towards a predetermined spot along that path constitutes a line-of-sight. The locations along the path where the viewer stands and looks are the control points of the line-of-sight profile.

**Scientific Perspective:** Scientific, linear, or size perspective is the reduction in the apparent size of objects as the distance from the observer increases. An object appears smaller and smaller as an observer moves further and further from it. At some distance, depending upon the size and degree of contrast between the object and its surroundings, the object may not be a point of interest for most people. At this hypothetical distance it can be argued that the object has little impact on the composition of the landscape of which it is a tiny part. Eventually, at even greater distances, the human eye is incapable of seeing the object at all.

**Viewshed:** A map that shows the geographic area from which a proposed action may be seen is a viewshed.

**Visual Assessments:** Analytical techniques that employ viewsheds, and/or line-of-sight profiles, and descriptions of aesthetic resources, to determine the impact of development upon aesthetic resources; and potential mitigation strategies to avoid, eliminate or reduce impacts on those resources.

**Visual impact:** Visual impact occurs when the mitigating effects of perspective do not reduce the visibility of an object to insignificant levels. Beauty plays no role in this concept. A visual impact may also be considered in the context of contrast. For instance, all other things being equal, a blue object

seen against an orange background has greater visual impact than a blue object seen against the same colored blue background. Again, beauty plays no role in this concept.

## **APPENDIX A**

# SCREENS

## THE RELATIONSHIP BETWEEN SCIENTIFIC PERSPECTIVE AND A LINE OF SIGHT PROFILE.

Scientific or linear perspective is a geometric procedure that projects space onto a plane. This technique provides the analyst with a simplified way to verify the effectiveness of applicants mitigation proposal.

Q: At what height should a screen be constructed to completely conceal a 23 foot object from an observer standing 80 feet from the object?  
 Constraint: Screen must be located 10 feet inside property line.

A: About 17 feet.

Q: What is the maximum height of an object to be concealed behind a 10 foot screen that is located 80 feet from an observer?  
 Constraint: The observer is standing about 18½ feet behind the screen.

A: About 23 feet.

Q: In approximately how many years would a vegetative screen 6 feet in height planted on a berm 4 feet in height completely conceal a 23 foot object?  
 Constraints: Berm must be located 10 feet inside property line; object is 80 feet from observer; expected vegetation growth rate of approximately 1 foot per year.

A: Approximately 7 years.

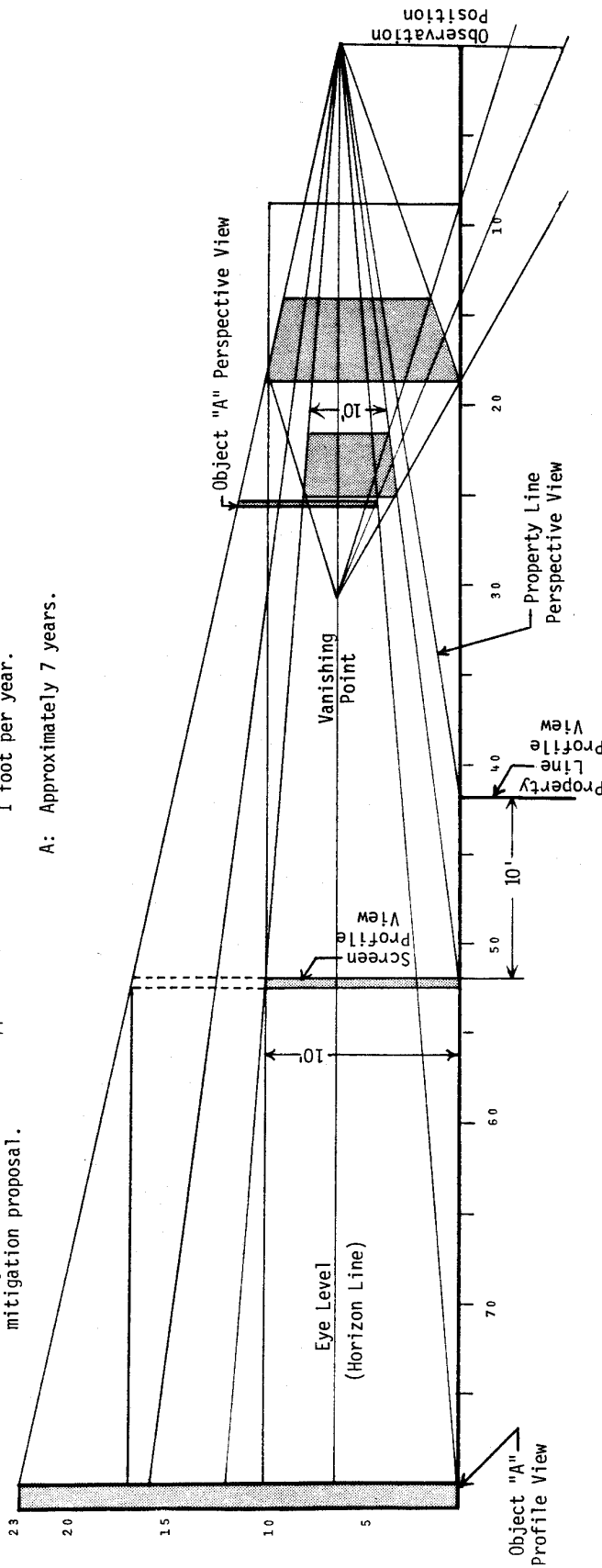

# VIEWSHEDS

For illustrative purposes only, a "partial" viewshed has been constructed below. A partial viewshed is distinguished from a full viewshed in that it only shows a selected area from which an object may be seen. A full viewshed shows all such areas.

The shaded area in the northwest corner of the lake is the only area within the lake that a hypothetical object 100 feet in height and situated at A (where the profile radii converge) may be seen.

The defined viewing area has been constructed by connecting each point along each profile where a viewer just begins to see the hypothetical object. To add realism to the viewshed, 40' vegetation has been factored into the lines of sight. The vegetation alters the viewing angle and hence the initial viewpoint indicated by the large black dots at the intersection of the shaded area with each profile radii.

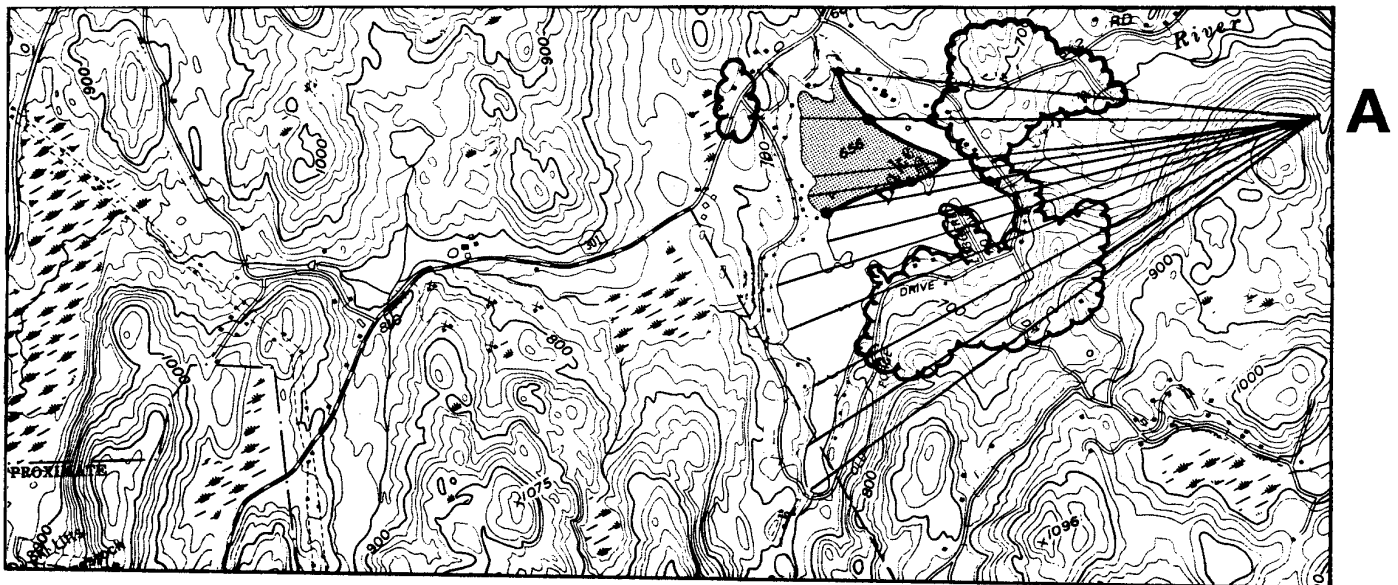

## LEGEND



VIEWSHED  
(Area within lake from which a hypothetical  
100 foot object located at "A" may be seen)



SCALE 1" = 2,000'

# PROFILES

To construct a profile, first position the graph paper parallel and contiguous to the horizontal alignment of the desired profile (indicated by line A-B). Proceed by extending vertical lines (indicated by dashed lines) to the correct height according to any selected convenient vertical scale (in this case 1" = 100'). This must be done from each spot where the horizontal alignment crosses a contour line. It is the elevation of the intersected contour that determines the height of each vertical line. Then, simply connect the top of each vertical line to form the profile (indicated by line C-D). The profile C-D depicts the depressions and elevations one would encounter walking a straight path from Point A to B on the plan map. To add realism add vegetation at the proper locations at the proper height (in this case 40').

## Sample Questions and Answers

According to the profile:

Q. Can an observer at location "Z" see the east shore of the lake?

A. No

Q. At what point will the observer no longer be able to see object "X"?

A. At point "Y".

Q. What is the visible portion of object "X" to an observer at location "Z"?

A. About 20 feet.

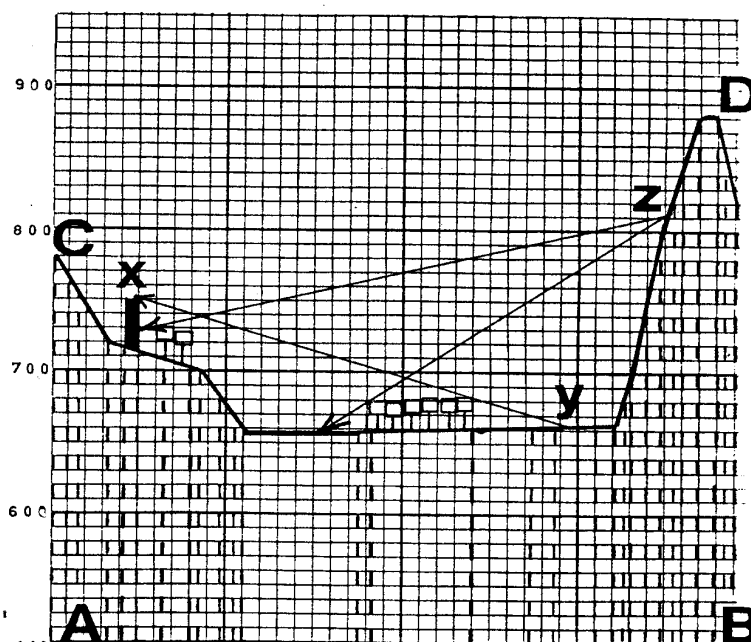

VERTICAL SCALE 1" = 100'  
HORIZONTAL SCALE 1" = 2,000'

